

## Integrated PWM module with CAN bus interface for control applications

### Features

- 4 PWM outputs 10-30 V, 3 A
  - 2 current stabilized
  - 4 high side switch
- 3 analogue inputs 0-10 V
- 8 V supply output for analogue inputs
- 4 galvanically separated digital inputs 10-30 V
  - 0 frequency / duty cycle inputs
- power supply 10-30 V
- CAN bus interface
  - secure MDCAN realtime protocol
  - MDFUNC series compatible
  - MDCAN series compatible
  - NAVIO series compatible
- configurable on-chip software
  - MDFUNC<sub>I/O</sub> input vs. output matrix
    - select an input out of more than 30 sources for each output channel or link function
    - several automatic control functions (P/PID/RPM)
    - latch function
    - triple station control
    - logic functions
    - transfer function (input vs. output)
    - RS232 interface or USB interface
  - configuration and monitoring with LC display
  - comfort configuration and monitoring with free PC-Tool
    - MDFUNC<sub>I/O</sub> Tool
    - easy to use
    - more possibilities, more functions
  - firmware upgrades
- status indication by LEDs
- safety feature for AIN/CANbus cable break
- mountable on 35 mm DIN-rail
- max. cable diameter for connectors: 1.5mm<sup>2</sup> with ferrule

### Applications

mobile and marine applications, hydraulic valve controls, motor controls, home control systems, dimmer controls, input/output CAN bus node

- control of hydraulic proportional valves
  - bow/stern thrusters
  - cylinders
  - winches
  - clutches
  - drives etc.
- position control of hydraulic cylinders
  - steering gears
  - compactors
- pressure control
- central switching
- control of DC-motors

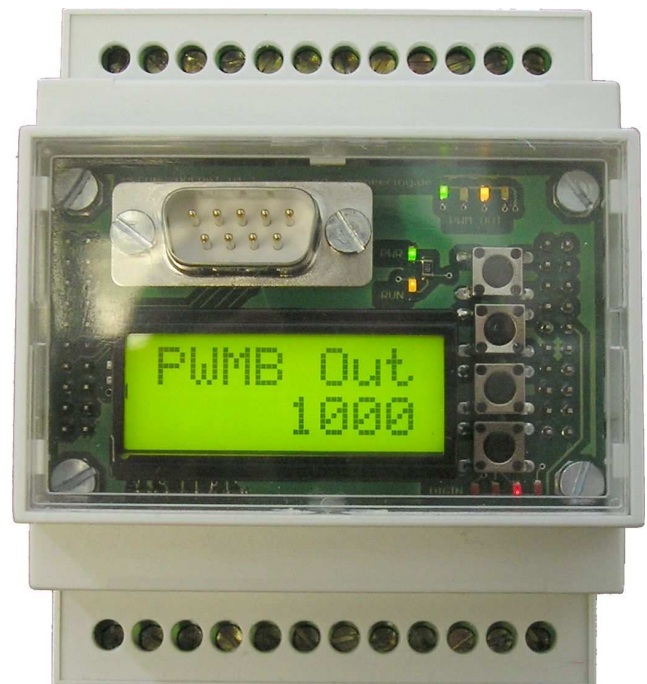

**Description**

The MDFUNC-PWM4cH unit is a pre-programmed and easy to use I/O module to control proportional functions with PWM outputs. Up to 4 inductive (e.g. coils) or non inductive loads can be controlled proportionally. Two of the outputs are **current controlled** (up to 3 A) with an adjustable deviance (less than 5 mA are possible). The automatic PI-control offers a fast step response. Additionally a **dither** signal can be added to **avoid sliding friction**.

Three analogue, four digital inputs and a CAN-interface are available. The MDFUNC-PWM4H uses the new MDFUNC<sub>I/O</sub>-engine, which offers more powerful possibilities for creating your control application. Functions like multiple station control, network control or positioning control are pre-programmed and easily accessible. The onboard LC-display has multiple language support (English, German, Dutch), offers monitoring functions and the possibility to change module parameters. For configuring the module more comfortable, the new PC-Tool MDFUNC<sub>I/O</sub> is available at the support site. A PC can be connected via RS232 serial port or via USB (hardware option).

Furthermore internal data can be displayed on the CAN-bus and multiple units can be linked to a network.

**Connection diagram**

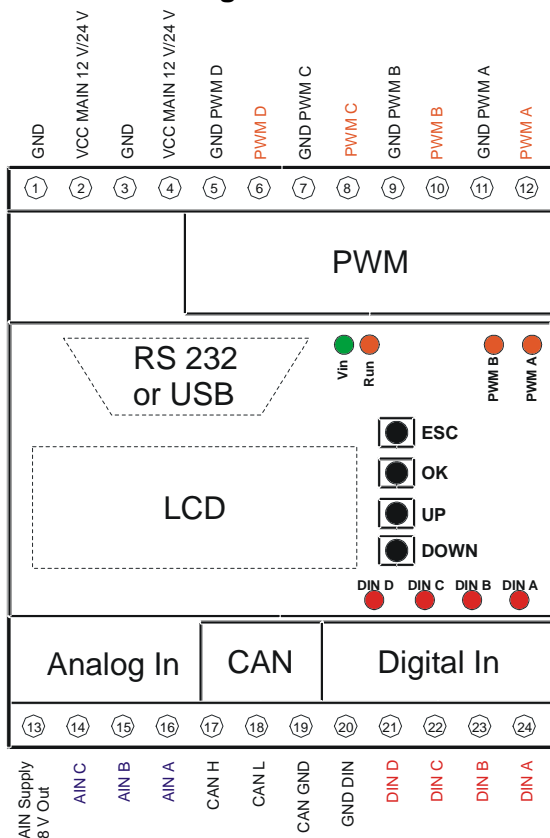

**Connector description**

**supply**

1,3	GND	main system and analogue input ground
2,4	V <sub>CC</sub> MAIN	main system supply

**inputs**

analogue inputs		
16,15,14	AIN A/B/C	analogue inputs
digital inputs		
24,23,22,21	DIN A/B/C/D	digital inputs
20	GND DIN	digital ground
CAN-Bus (I/O)		
17,18	CANH,CANL	CAN bus connectors
19	CAN GND	CAN bus ground

**outputs**

13	AIN Supply 8V	supply for passive analogue devices: e.g. joysticks, potentiometers etc.
12,10	PWM A,B	PWM outputs
8,6	PWM C,D	PWM outputs <b>(current controlled)</b>
11,9,7,5	GND PWM A,B,C,D	PWM ground

**Button description**

- UP/DOWN: switch through current menu / in/decrease a value
- OK: jump in submenu / select value for edit / accept edited value
- ESC: jump out of submenu / cancel value edit

**Software assignments**

- Output A: free, calculation channel
- Output B: free, calculation channel
- Output C: free, calculation channel
- Output D: free, calculation channel
- Output E: free, calculation channel

## Electrical Characteristics

(T<sub>env</sub> = 25°C)

### Power supply

Symbol	Parameter	min	typ.	max.	abs max.	Unit
V <sub>In</sub>	system power supply voltage DC	10	12/24	30	40	V
I <sub>In</sub> @ 12 V	system current (with LCD)		300			mA
I <sub>In</sub> @ 24 V	system current (with LCD)		150			mA
T <sub>env</sub>	environment temperature	-10	25	50	60	°C

### PWM A/B/C/D

- high side switches

Symbol	Parameter	min	typ.	max.	abs max.	Unit
V <sub>CC,PWM</sub>	PWM-stage supply voltage DC	10	12/24	30	40	V
I <sub>CC,PWM</sub> (both inputs connected)	PWM-stage supply current	-	-	9	13	A
I <sub>PWM A/B/C</sub>	current per channel	20	-	3000	5000	mA
t <sub>on</sub>	turn on- switching time <sup>3</sup>	-	140	-	-	µs
t <sub>off</sub>	turn off- switching time <sup>3</sup>	-	70	-	-	µs
R <sub>on</sub>	impedance during "on state"	-	30	50	-	mΩ
f <sub>PWM,A/B</sub> <sup>1</sup>	frequency range channel A and B	1	-	2000	-	Hz
f <sub>PWM,C</sub> <sup>2</sup>	frequency range channel C	15	-	1950	-	Hz

<sup>1</sup> resolution: 1 Hz

<sup>2</sup> six frequencies available: 15 Hz, 66 Hz, 122 Hz, 244 Hz, 488 Hz, 1950 Hz

<sup>3</sup> 10 % V<sub>CC,PWM</sub> to 90 % V<sub>CC,PWM</sub> (@V<sub>CC,PWM</sub> = 13 V)

### Digital Inputs A/B/C/D

- inputs galvanically separated

Symbol	Parameter	min	typ.	max.	abs max.	Unit
V <sub>DIN,H</sub>	voltage for high level	3.5	12/24	28	32	V
V <sub>DIN,L</sub>	voltage for low level	-0.5	0	2.5	-	V
t <sub>S,DIN</sub>	turn on/off time (sample time)	-	1	3	-	ms
I <sub>DIN</sub> @ 24 V	current per channel	1.0 <sup>1</sup>	11.0 <sup>2</sup>	12	-	mA

<sup>1</sup> @V<sub>DIN</sub> = 3.5 V

<sup>2</sup> optocoupler: 5.5 mA, LED: 5.5 mA

### Analog Inputs A/B/C

- averaged values
- overvoltage protected input

Symbol	Parameter	min	typ.	max.	abs max.	Unit
V <sub>AIN</sub>	analog input voltage	0	-	10	11	V
R <sub>AIN</sub>	input impedance	50 <sup>4</sup>	94	110	-	kΩ
f <sub>Sample</sub>	internal register update frequency	-	400	-	-	Hz

<sup>4</sup> input impedance decreases, when V<sub>AIN</sub> is higher than 11.2 V

**AIN supply output**

- $V_{\text{sup,AIN}} = 8 \text{ V}$
- $I_{\text{sup,AIN,max}} = 90 \text{ mA}$
- output not galvanically separated

**CAN bus interface**

- galvanically separated
- connectors with CANH and CANL
- max. bus length: 40 m..1000 m
- selectable CAN bus speed: 50, 125, 250, 500, 1000 kBit/s
- blinking RUN-LED and blinking antenna symbol on LCD, when bus OK
- 3 free 16 bit inputs (MDCAN protocol)
- 3 free 8 bit inputs (MDCAN protocol)
- MDCAN protocol output (10 Hz):
  - analog inputs A/B/C
  - digital inputs (A/B/C/D)
  - frequency input (DINA)
  - latch status results (A/B/C/D/E)
  - output channels (A/B/C/D/E)

**RS232 connection**

- not galvanically separated  
**ATTENTION** when using PC with grounded outlet power supply  $GND_{\text{PC}}$  must have the same potential as  $GND_{\text{PWM3}}$ .  
If the difference is more than 100 mV you can damage the AOUT2 and your PC. Best use a laptop powered by battery.
- SUB-D 9 pin male connector on board
- connect common zero modem cable to port (also possible with "USB/RS232" adapter)
- data connection: 57600,8,N,1

**USB connection**

- not galvanically separated  
**ATTENTION** when using PC with grounded outlet power supply  $GND_{\text{PC}}$  must have the same potential as  $GND_{\text{PWM3}}$ .  
If the difference is more than 100 mV you can damage the AOUT2 and your PC. Best use a laptop powered by battery.
- Mini-USB connector 5 pin on board
- USB 1.1 standard
- connect AOUT2 with common Mini-USB cable to your PC
- on board USB/RS232 adapter, device will appear as COM-port on your PC
- RS232 data connection: 57600,8,N,1
- driver for free download

## Setup Program: MDFUNC-I/O Tool Version 2.3

- more possibilities, better overview
- easy user interface
- free input-output combinations
- inputs from local analogue inputs, digital inputs, CAN bus inputs or system outputs for feedback
- Boolean operations, latch function
- CAN bus inputs/outputs
- Input vs. Output transfer function
- Ramp functions with gain and offset limitation
- monitor functions
- load/save settings from/to file
- special functions: automatic control, multiple station control
- Requirements:
  - Win2000/XP
  - CPU with 600 MHz or higher
  - COM port or USB port

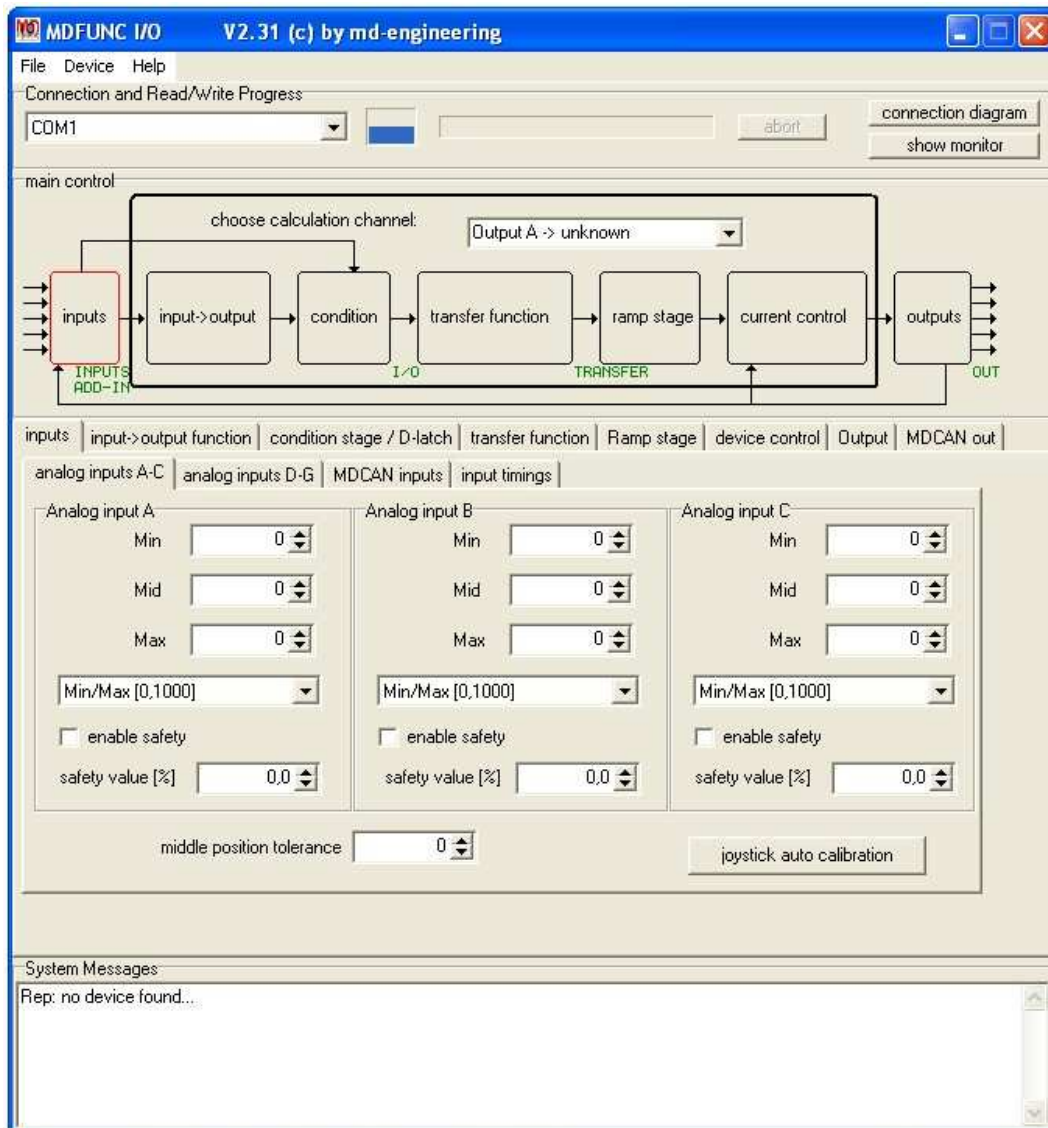

**Package dimensions (in mm)**

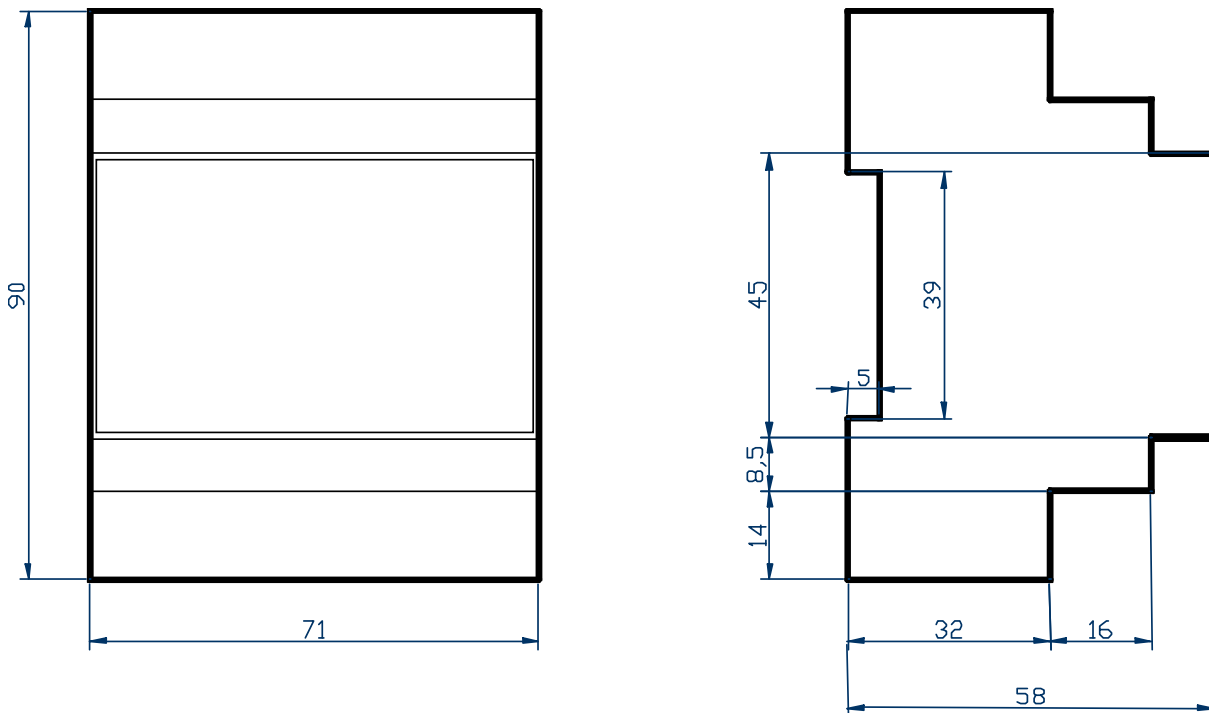

**Order codes**

**PWM4cH with RS232 connector**

MDFUNC-PWM4cH-RS232-LCD

**PWM4cH with USB-connector**

MDFUNC-PWM4cH -USB-LCD

**RS232-PC connection cable**

MDCABLE-RS232-ZERO

**USB-PC connection cable**

MDCABLE-MiniUSB

Please ask for special device programming, other CAN protocol stacks or our "low cost solutions" (e.g. not galvanically separated or no LCD).

**Support**

Get datasheets, drivers, firmware, software and examples from:

[www.md-engineering.de](http://www.md-engineering.de)